

BARGHEST PIVOT KIT INSTRUCTIONS

RETAILER: These instructions MUST BE provided to the end user.

Thank you for purchasing a Barghest. We want to give you important information about your bike...

⚠ WARNING: CYCLING CAN BE DANGEROUS. BICYCLE PRODUCTS SHOULD BE INSTALLED AND SERVICED BY A PROFESSIONAL MECHANIC. NEVER MODIFY YOUR BICYCLE OR ACCESSORIES. READ AND FOLLOW ALL PRODUCT INSTRUCTIONS AND WARNINGS INCLUDING INFORMATION ON THE MANUFACTURER'S WEBSITE. INSPECT YOUR BICYCLE BEFORE EVERY RIDE. ALWAYS WEAR A HELMET.

Additional Product and Safety Information can be found at the website: hellerbikes.com/safety

Compatibility & Intended Use

This service kit is compatible with the following Heller 4-Bar suspension frames: Model year 2017+ Barghest (all models and spec levels).

NOTE 1: Replacement bearings are NOT included in this kit. Replacement bearings must be purchased separately. For information regarding bearing size refer to Figure 1 on the following pages.

NOTE 2: A replacement derailleur hanger and replacement housing guides are NOT included in this kit. The items are available separately. See Figure 1 for more details.

Tools Required

See Tools column in the table of Figure 1.

Installation

Before you begin working on the bike:

⚠ WARNING: Failure to use thread locking compound according to these instructions could cause pivot bolts to loosen or fall out, leading to a crash or damage to the frame.

- Review Figure 1 and the accompanying table. Details regarding the tools and consumables (grease, thread lock) required to properly service the pivots of the Heller 4-Bar frame can be found in these exploded views and the accompanying tables. Do not attempt to service the frame pivots if you lack any of these tools or supplies.
- A bearing puller, bearing press, and knowledge of how to properly use these tools are required to change the cartridge bearings in a Heller 4-Bar frame. If you do not have these tools, or do not know how to properly remove and install cartridge bearings with them, do not attempt to replace the bearings in the frame.
- A torque wrench is required to service the pivots of Heller 4-Bar frames. If you do not have a torque wrench or knowledge of how to properly operate it, do not attempt to service the pivots of the frame.

Ongoing Maintenance

Check pivots before every ride, tighten to specified torque as needed. Applying thread lock as described helps to prevent bolts from loosening during normal riding conditions.

A small amount of grease on pivot contact faces can help quiet the pivot when riding in dry conditions.

Inspect pivot hardware for wear/damage at least annually. If pivot hardware becomes damaged, stripped, or develops play that cannot be eliminated with the proper torque specification, replace the affected part(s).

Check bearings for smooth operation at least annually (more often depending on frequency and riding environment). If bearings are rough, seized, or there is slop between the inner and outer bearing race, replace as needed.

Warranty Information

Proof of purchase is required before a warranty claim is processed. Heller Bikes therefore strongly encourages warranty registration at hellerbikes.com. Failure to register will not affect consumer rights under the limited warranty, so long as the consumer can show in a reasonable manner proof of original ownership and the date the Heller Bikes product was purchased.

If you have any questions contact support@hellerbikes.com

Heller Barghest Service Kit Parts

Item #	QTY	Description	Size	Preparation	Torque	Tool Required	Notes
1	1	Cable Port Cover	-	-	-	-	-
2	7	Cable Port Guide	-	-	-	-	-
3	1	Cable Port Guide @ BB	-	-	-	-	-
4	10	Cable Port Bolt	M3 x 0.5 - 8L	Grease	1 Nm	M2 Hex	-
5	1	Upper Shock Mount Nut	-	-	-	-	-
6	4	Rocker Pivot Bolt	-	Grease OD & Flange; Threads: Loctite 242 Blue	12 Nm	M5 Hex	-
7	4	Rocker Pivot Washer	-	Grease OD & ID	-	-	-
8	11	Pivot Bearing	Ø21 x Ø12 x 5w	Grease OD	-	Bearing Press/ Puller	QBP # BB8801, Not Included in Pivot Service Kit
9	4	Pivot Nut	-	-	-	-	-
10	1	Lower Shock Mount Bolt	-	Loctite 242 Blue	8 Nm	M6 Hex	-
11	1	Upper Shock Mount Bolt	-	Loctite 242 Blue	8 Nm	M5 Hex	-
12	2	FD Bolt	M5 x 0.8 - 20L	Loctite 242 Blue	4 Nm	M4 Hex	-
13	1	FD High Direct Mount/Cover	-	-	-	-	Cover not shown
14	1	Main Pivot Nut	-	-	-	-	-
15	2	Main Pivot Washer	-	Grease OD & ID	-	-	-
16	1	Main Pivot Spacer	-	-	-	-	Pressed into frame, not replaceable
17	1	Main Pivot Bolt Split Washer	-	Grease OD & ID	-	-	-
18	1	Main Pivot Bolt	-	Grease OD & Flange; Threads: Loctite 242 Blue	-	M6 Hex	-
19	2	CS Pivot Bolt	-	Grease OD & Flange; Threads: Loctite 242 Blue	-	M5 Hex	-
20	4	CS Pivot Bolt Flat Washer	-	-	-	-	-
21	4	CS Pivot Flanged Washer	-	Grease Faces	-	-	Flange faced away from bearing

Item #	QTY	Description	Size	Preparation	Torque	Tool Required	Notes
22	1	RD Hanger Securing Nut	-	-	-	-	-
23	2	RD Hanger	-	-	-	-	-
24	3	RD Hanger Bolt	M4 x 0.7 - 15L	Loctite 242 Blue	4 Nm	M2.5 Hex	-
25	1	Rear Shock (Not Shown)	200 x 51 mm	-	-	-	Contact Heller customer service for brand specific shock tunes
26	1 Kit	Upper Shock Mount Spacer (Not Shown)	30.0 x 8 mm	Per Shock Manufacturer	-	Per Shock Manufacturer	Sold separately, per shock Manufacturer
27	1 Kit	Lower Shock Mount Spacer (Not Shown)	25.4 x 8 mm	Per Shock Manufacturer	-	Per Shock Manufacturer	Sold separately, per shock Manufacturer

OD = Outer Diameter, Unthreaded Sections
ID = Inner Diameter, Unthreaded Sections

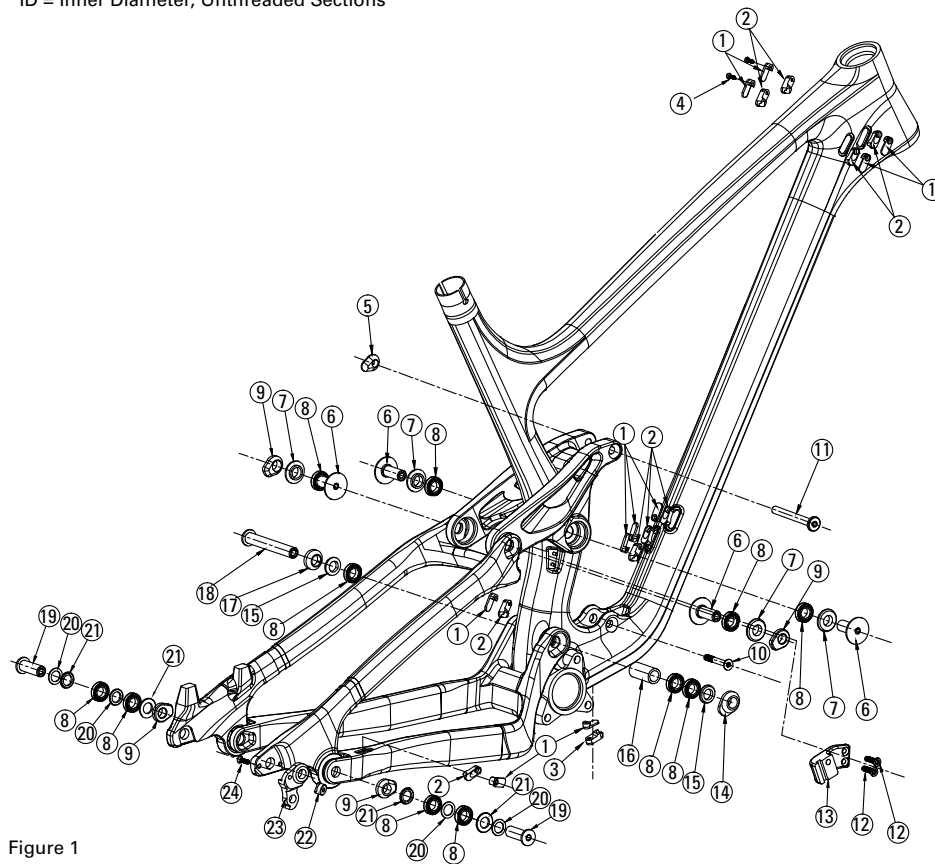

Figure 1